

Lhotse LDLH-46

GCL



STANDARD FEATURES

- working temperature – straight module: from 0°C to 2°C; corner modules from 4°C to 8°C
- refrigerant: R744
- electrical defrosting
- 2 x NTC temperature probe
- siphoned condensate drains
- exposition: zinc-plated steel, powder coated in white (RAL 9003)
- worktop: linen stainless steel
- expositions full base

OPTIONS

- electronic expansion valve
- LEDit lighting
- PVC floor profiles
- bumper
- sidewalls

Lhotse LDLH-46 2500 GCL

GCL – glass | single, bent | lift up

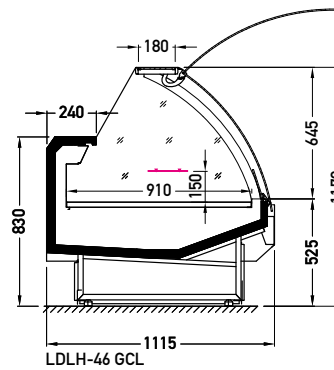

AVAILABLE MODULES

1250 1875 2150 2500 3750