



REMOTE → COUNTERS

Lhotse LDLH-46 2500

GCL | BCA



Module:

2500



Refrigerant:

R744



Available options:

- working temperature – straight module: from 0°C to 2°C; corner nodules from 4°C to 8°C
- electrical defrosting
- electronic expansion valve
- 2 x NTC temperature probe
- siphoned condensate drains
- exposition: zinc-plated steel, powder coated in white (RAL 9003)
- worktop: linen stainless steel
- LEDit lighting (optionally)
- expositions full base
- without sidewalls (optionally)



Lhotse LDLH-47 2500 GCL



Cross sections:

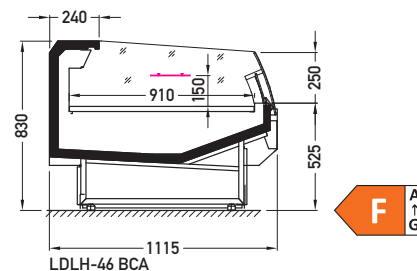
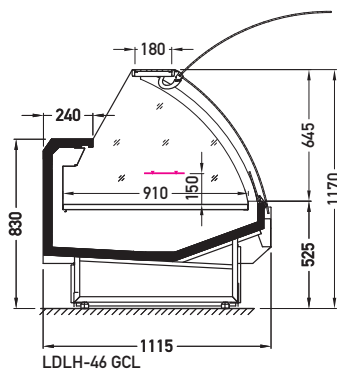

GCL – glass | single, bent | lift up

BCA – low glass or front glass riser | single, bent | fixed

Available modules: 1250 1875 2150 2500 3750