



REMOTE → COUNTERS

Lhotse LDLH-36 1250 GSP



Module:

1250



Refrigerant:

R744



Available options:

- working temperature: from 0°C to 2°C
- electrical defrosting
- mechanical expansion valve for HFC; for R744 units electronic expansion valve
- 2 x NTC temperature probe
- **energy saving fans**
- siphoned condensate drains
- exposition: zinc-plated steel, powder coated in white (RAL 9003)
- worktop: linen stainless steel
- without a possibility to install lighting
- exposition on a full base
- without sidewalls (optionally)

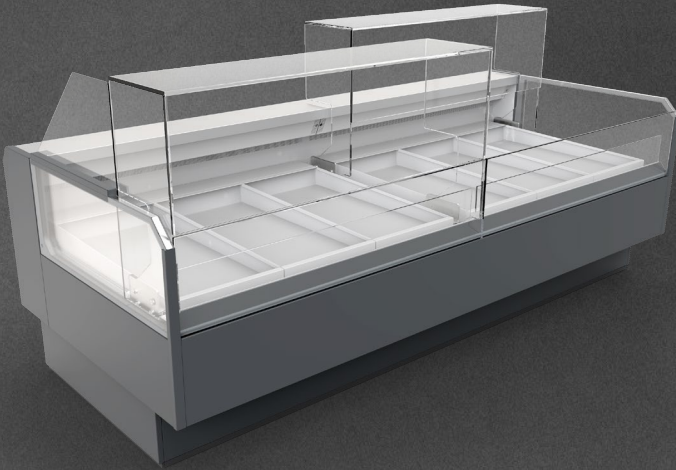

Lhotse LDLH 36 2500 GSP



Cross sections:

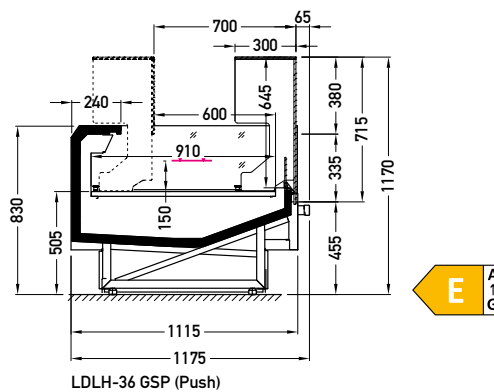

GSP – glass | single, straight | sliding (slide-up/push)

Available modules: 1250 1875 2500 3750