

Lhotse LDLH-12

CSS | BCA



STANDARD FEATURES

- working temperature: from 0°C to 2°C
- refrigerant: R744
- electrical defrosting
- 2 x NTC temperature probe
- siphoned condensate drains
- 2 exposition: zinc-plated steel, powder coated in white (RAL 9003)
- worktop: linen stainless steel
- exposition on the full base
- mechanical night blind in cassette for version BCA
- cascade 3-levels zinc steel (RAL 9003) for version BCA

OPTIONS

- electronic expansion valve
- LEDit lighting
- PVC floor profiles
- bumper
- sidewalls

Lhotse LDLH-12 2500 CSS

CSS – cover | single, straight | sliding (sideways)
 BCA – low glass or front glass riser | single, bent | fixed

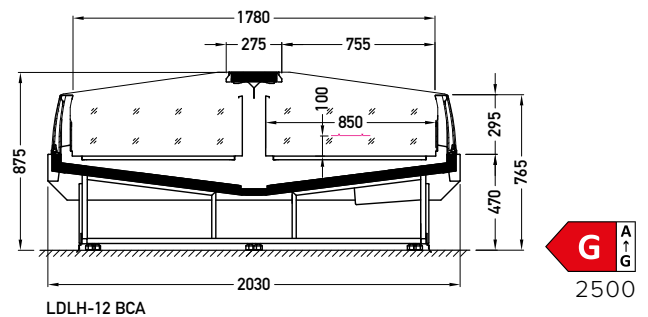
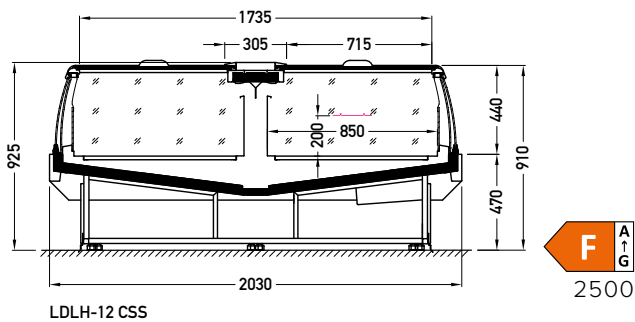

AVAILABLE MODULES

1875 2500 3750
 1930G