



PLUG-IN → COUNTERS

# Grazia LDGR-29 1250

GSL | BSA



**Module:**

1250



**Refrigerant:**

R290



**Available options:**

- working temperature – straight module and corners from 0°C to 2°C
- electrical defrosting
- automatic evaporation of condensate
- electronic controller with temperature indicator
- exposition: zinc-plated steel, powder coated in white (RAL 9003)
- storage: steel coated in grey
- worktop: linen stainless steel
- **top LEDit lighting** (optionally)
- color of the base black (RAL 9005)
- no PVC floor profiles (optionally)
- without perspex covers (optionally)
- without sidewalls (optionally)
- bumper (optionally)

Grazia LDGR-29 2500 GSL



**Cross sections:**

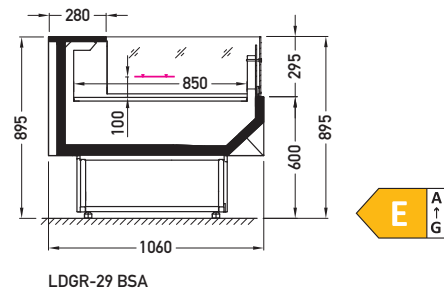
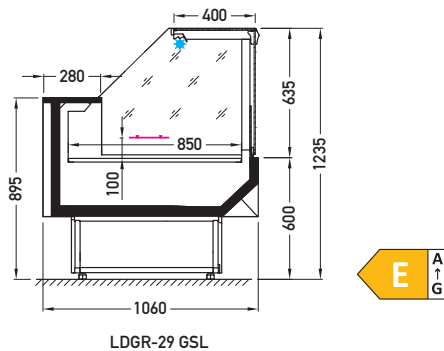

**GSL** – glass | single, straight | lift up

**BSA** – low glass or front glass riser | single, straight | fixed

**Available modules:** **BSA GSL** 1250 1875 2500 3750  
 NW45 NZ45  
**GSL** NZ90