



REMOTE → COUNTERS

Grazia LDGR-09 1250 GCL



Module:

1250



Refrigerant:

R744



Available options:

- working temperature – straight module and corners from 0°C to 2°C
- electrical defrosting
- electronic expansion valve
- 2 x NTC temperature probe
- siphoned condensate drains
- exposition: zinc-plated steel, powder coated in white (RAL 9003)
- worktop: linen stainless steel
- lighting optionally – LEDit (top)
- color of the base black (RAL 9005)
- no PVC floor profiles (optionally)
- without perspex covers (optionally)
- without sidewalls (optionally)
- bumper (optionally)



Grazia LDGR-09 2500 GCL



Cross sections:

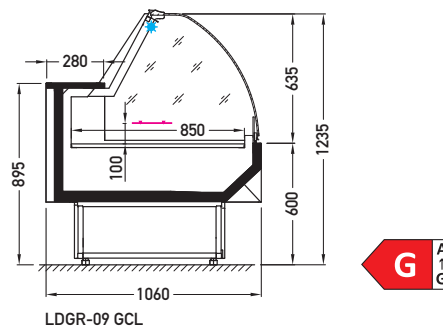

GCL – glass | single, bent | lift up

Available modules: 1250 1875 2500 3750
NW45 NZ45