



PLUG-IN → PASTRY LINE

Elegant RDEL-05 1400 GBT



Elegant RDEL-05 1400 GBT



Module:

1400



Refrigerant:

R290



Available options:

- working temperature – straight modules from 0°C to 2°C; corner NW45 from 2°C to 4°C; corner NZ45 from 4°C to 8°C
- electrical defrosting
- automatic evaporation of condensate
- electronic controller with temperature indicator
- **energy saving fans**
- exposition: 3 suspended glass shelves + bottom made of powder coated, zinc-coated metal plate
- shelves support and bottom shelf in grey color RAL 7004
- back doors, sliding, double glazed (in corner and 0600 modules hinged door)
- **lighting – top and each shelf – energy-saving, LEDit, WW-2**
- sidewalls integrated with thermopane glass, with screen printing



Cross sections:

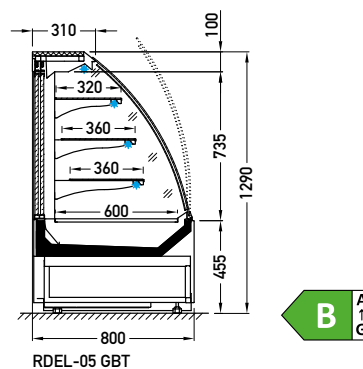

GBT – glass | double, bent | tilt

Available modules: 0600 0900 1400
NW45 NZ45